

# **DIGITAL** **PROJECTION**

***M-Vision 21000 II Series WUXGA***  
***M-Vision 24000 Series WUXGA***  
***M-Vision 27000 Series WUXGA***

IMPORTANT INFORMATION

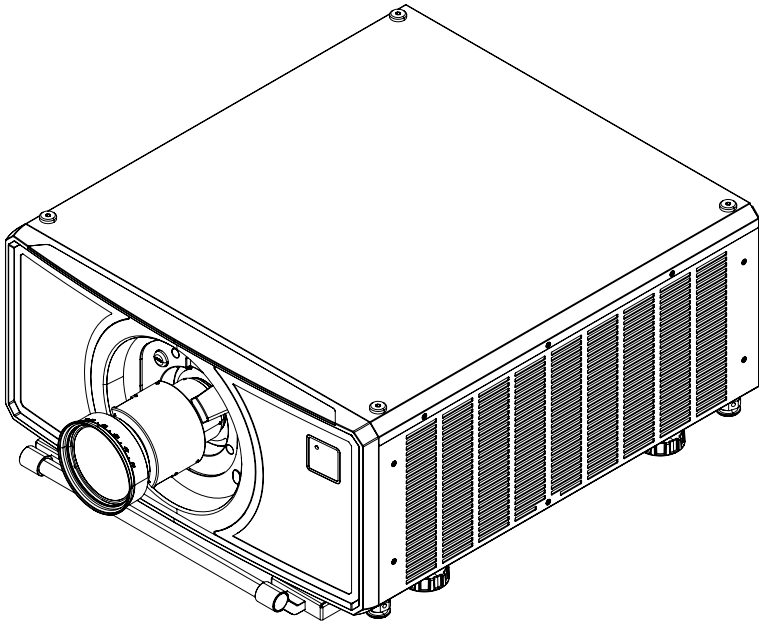

A brand of  **DELTA**

This page is intentionally left blank

## Introduction

Congratulations on your purchase of this Digital Projection product.

The information in this document is relevant for the following products:

- M-Vision 21000 II Series WUXGA (EMEA and China)
- M-Vision 21000 II Series WUXGA (USA TAA compliant)
- M-Vision 21000 II Series WUXGA (USA TAA compliant - REF)
- M-Vision 24000 Series WUXGA (EMEA and China)
- M-Vision 24000 Series WUXGA (USA TAA compliant)
- M-Vision 24000 Series WUXGA (USA TAA compliant - REF)
- M-Vision 27000 Series WUXGA (EMEA and China)
- M-Vision 27000 Series WUXGA (USA TAA compliant)
- M-Vision 27000 Series WUXGA (USA TAA compliant - REF)



*This projector is a Laser Risk Group 2 product when a lens with a throw ratio less than 1.2:1 is installed. It becomes Laser Risk Group 3 when a lens with a throw ratio greater than 1.2:1 is installed. Additional installation and operational precautions must be followed when the projector is classed as Laser Risk Group 3. This information is provided in this document and in the User Manual.*



*Please note that the REF model is always classed under Laser Risk Group 2.*

## Symbols used in this document

Some information in this document may be accompanied by the following symbols:



**LASER WARNING:** this symbol indicates that there is a potential hazard of eye exposure to laser radiation unless the instructions are closely followed.



**ELECTRICAL WARNING:** this symbol indicates that there is a danger of electrical shock unless the instructions are closely followed.



**WARNING:** this symbol indicates that there is a danger of physical injury to yourself and/or damage to the equipment unless the instructions are closely followed.



*NOTE: this symbol indicates that there is some important information that you should read.*

## Additional Documentation

Full information about operating, connecting and setting up the projector can be found in the User Guides.

Please use the QR code (also located on the projector) to access the latest M-Vision projector user guides and other documentation via the Digital Projection website.



Or visit the Digital Projection website to download the latest user guide and other documentation.

## Legal notice

Trademarks and trade names mentioned in this document remain the property of their respective owners. Digital Projection disclaims any proprietary interest in trademarks and trade names other than its own.

Copyright © 2024 Digital Projection Ltd. All rights reserved.

## Third Party Credits

DMD™, Digital Micromirror Device™ and DLP™ are trademarks of Texas Instruments Inc.

Art-Net™ Designed by and Copyright Artistic License Holdings Ltd.

etherCON™ Designed by and Copyright Neutrik AG.

# Contents

<b>Introduction</b> .....	<b>3</b>
<i>Symbols used in this document</i> .....	3
<i>Additional Documentation</i> .....	4
<i>Legal notice</i> .....	4
<i>Third Party Credits</i> .....	4
<b>Contents</b> .....	<b>5</b>
<b>What's in the box?</b> .....	<b>7</b>
<b>Electrical and Physical Specifications</b> .....	<b>8</b>
<b>General Precautions</b> .....	<b>11</b>
<b>Laser Safety Precautions</b> .....	<b>13</b>
<i>Laser Risk Group 2 Precautions</i> .....	13
<i>Laser Risk Group 3 Precautions</i> .....	14
<i>Laser Parameters</i> .....	15
<i>Light Output</i> .....	15
<i>Laser Power</i> .....	15
<b>Compliance with International Standards</b> .....	<b>16</b>
<i>RF Interference</i> .....	16
<i>Noise</i> .....	16
<i>European Waste Electrical and Electronic Equipment (WEEE) Directive</i> .....	16
<b>Product Labels</b> .....	<b>17</b>
<i>Projector</i> .....	17
<i>Label Locations</i> .....	23
<i>Projector - REF Model</i> .....	24
<i>Label Locations - REF Model</i> .....	27
<b>Location of Laser Aperture</b> .....	<b>28</b>
<b>Interlock Switches</b> .....	<b>29</b>
<b>Installation Precautions</b> .....	<b>30</b>
<b>Laser Hazard Installation Precautions</b> .....	<b>34</b>
<i>Laser Risk Group 2 Installation</i> .....	34
<i>Laser Risk Group 3 Installation Precautions</i> .....	34
<i>Light Hazard Warning</i> .....	35
<i>Light Hazard Distance and Hazard Zone</i> .....	35
<i>Restriction Zone</i> .....	36

---

<b>Fitting a lens</b> .....	<b>37</b>
<i>Inserting a new lens</i> .....	38
<i>Removing the lens</i> .....	39
<b>Positioning the screen and projector</b> .....	<b>40</b>
<b>Stacking</b> .....	<b>41</b>
<i>Pin and cup stacking</i> .....	41
<b>Signal connections</b> .....	<b>44</b>
<b>Control connections</b> .....	<b>46</b>
<b>AC Power Precautions</b> .....	<b>47</b>
<i>Connecting the power supply</i> .....	47
<b>Basic Operating Instructions</b> .....	<b>48</b>
<i>Switching the projector on</i> .....	48
<i>Switching the projector off</i> .....	48
<i>Interlock reset</i> .....	48
<i>Selecting an input signal</i> .....	49
<i>Selecting a test pattern</i> .....	49
<i>Adjusting the lens</i> .....	50
<i>OSD Lens menu</i> .....	50
<i>Adjusting the image</i> .....	50
<i>Orientation</i> .....	50
<i>Geometry</i> .....	50
<i>Picture</i> .....	50
<b>Operating the projector</b> .....	<b>51</b>
<i>Control panel</i> .....	52
<i>Projector indicators</i> .....	54
<i>Remote control</i> .....	55
<b>Contact Information</b> .....	<b>60</b>

# What's in the box?

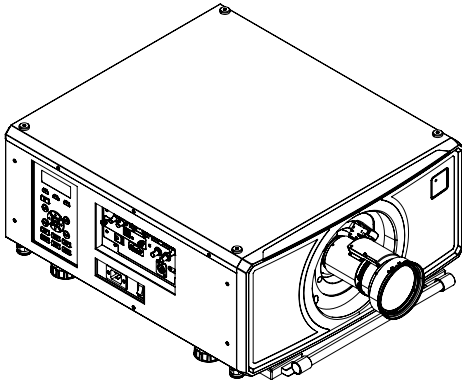

**Projector**

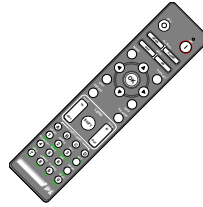

**Remote Control**

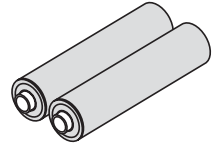

**Batteries  
(2xAAA)**

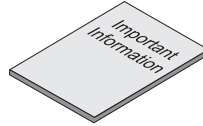

**Important  
Information Book**

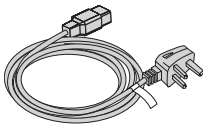

**Power Cable, UK**

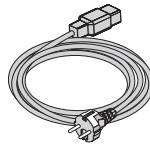

**Power Cable, Europe**

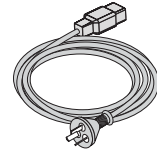

**Power Cable, China**

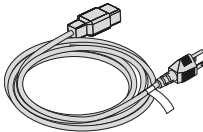

**NEMA 5-15P - C19 Power  
Cable, North America**

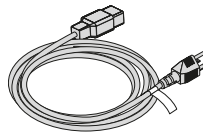

**NEMA 6-15P - C19 Power  
Cable, North America**

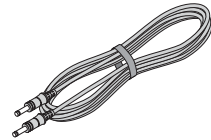

**Remote Control Cable**

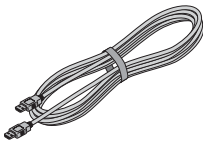

**HDMI Cable**



A single power cable is supplied with the projector. The cable appropriate for the destination territory is supplied.



The M-Vision Laser Stacking Kit is available as an optional extra (part number: 119-073A). Please contact your local representative for details.

## Electrical and Physical Specifications

	<b>M-Vision 21000 II Series WUXGA</b>	<b>M-Vision 24000 Series WUXGA</b>
Mains Voltage	110-240 VAC 50/60Hz 110-130 VAC 11.1 A 50/60Hz	
Operating Temperature	0°C to 40°C (32 F to 104 F), 40°C to 45°C (104 F to 113 F) with reduced light output 33°C to 40°C (91°F to 104°F) automatically reduced to ECO mode light output	
Storage Temperature	-20°C to 60°C (-4 F to 140 F)	
Operating Humidity	10% to 90% non-condensing	
Storage Humidity	10% to 90% non-condensing	
Dimensions	W 748 mm (29.4 in), H 248 mm (9.8 in), D 530 mm (20.9 in)	
Weight	47.2 kg (104 lb) without lens	
Power Consumption	at 110VAC: typical 650 W, max 715 W, in Normal mode at 110VAC: typical 980 W, max 1080 W, in High Altitude mode at 220VAC: typical 1300 W, max 1430 W, in Normal mode at 220VAC: typical 1000 W, max 1100 W, in ECO mode at 220VAC: typical 1600 W, max 1760 W in High Altitude mode	at 110VAC: typical 930 W, max 1055 W, in Normal mode at 110VAC: typical 1200 W, max 1320 W, in High Altitude mode at 220VAC: typical 1450 W, max 1595 W, in Normal mode at 220VAC: typical 1050 W, max 1155 W, in ECO mode at 220VAC: typical 1750 W, max 1935 W, in High Altitude mode
Standby Power	<1W in Super ECO mode, <6W in ECO mode, <40W in Normal mode	



	<b>M-Vision 21000 II Series WUXGA</b>	<b>M-Vision 24000 Series WUXGA</b>
Thermal Dissipation	at 110 VAC: typical 2218 BTU/hr, max 2440 BTU/hr, in Normal mode at 110 VAC: typical 3344 BTU/hr, max 3685 BTU/hr, in High Altitude mode at 220 VAC: typical 4436 BTU/hr, max 4879 BTU/hr, in Normal mode at 220 VAC: typical 3412 BTU/hr, max 3753 BTU/hr, in ECO mode at 220 VAC: typical 5459 BTU/hr, max 6005 BTU/hr, in High Altitude mode	at 110 VAC: typical 3173 BTU/hr, max 3600 BTU/hr, in Normal mode at 110 VAC: typical 4094 BTU/hr, max 4504 BTU/hr, in High Altitude mode at 220 VAC: typical 4947 BTU/hr, max 5442 BTU/hr, in Normal mode at 220 VAC: typical 3583 BTU/hr, max 3941 BTU/hr, in ECO mode at 220 VAC: typical 5971 BTU/hr, max 6602 BTU/hr, in High Altitude mode
Fan Noise	typical 44dB, max 46db in Normal mode typical 42dBA, max 44dBA in ECO mode	typical 47dBA, max 49dBA in Normal mode typical 45dBA, max 47dBA in ECO mode

	<b>M-Vision 27000 Series WUXGA</b>
Mains Voltage	110-240 VAC 50/60Hz 110-130 VAC 11.1 A 50/60Hz
Operating Temperature	0°C to 40°C (32 F to 104 F), 40°C to 45°C (104 F to 113 F) with reduced light output 33°C to 40°C (91°F to 104°F) automatically reduced to ECO mode light output
Storage Temperature	-20°C to 60°C (-4 F to 140 F)
Operating Humidity	10% to 90% non-condensing
Storage Humidity	10% to 90% non-condensing
Dimensions	W 748 mm (29.4 in), H 248 mm (9.8 in), D 530 mm (20.9 in)
Weight	47.2 kg (104 lb) without lens
Power Consumption	at 110VAC: typical 850 W, max 935 W, in Normal mode at 110VAC: typical 1150 W, max 1265 W, in High Altitude mode at 220VAC: typical 1550 W, max 1705 W, in Normal mode at 220VAC: typical 1150 W, max 1265 W, in ECO mode at 220VAC: typical 1850 W, max 2035 W, in High Altitude mode
Standby Power	<1W in Super ECO mode, <6W in ECO mode, <40W in Normal mode

<b>M-Vision 27000 Series WUXGA</b>	
Thermal Dissipation	at 110 VAC: typical 2900 BTU/hr, max 3190 BTU/hr, in Normal mode at 110 VAC: typical 3924 BTU/hr, max 4316 BTU/hr, in High Altitude mode at 220 VAC: typical 5289 BTU/hr, max 5818 BTU/hr, in Normal mode at 220 VAC: typical 3924 BTU/hr, max 4316 BTU/hr, in ECO mode at 220 VAC: typical 6312 BTU/hr, max 6944 BTU/hr, in High Altitude mode
Fan Noise	typical 48dBA, max 50dBA in Normal mode typical 46dBA, max 48dBA in ECO mode



*Specifications are subject to change without notice.*

## General Precautions



**Warning! Death or Serious Injury could occur if the following precautions are ignored**



**Eye Hazard! Do not look directly into the lens when the light source is on. The high brightness can cause permanent eye damage**



**Fire Hazard! Keep any combustible material away from hot surfaces and the projected beam. Ensure cables do not contact hot surfaces**



**Shock Hazard! Use only authorized components, tools, accessories and replacement parts specified by the manufacturer**



**Trip Hazard! Locate cables where they cannot be pulled, tripped over or damaged by persons or objects**

**Operate the product in the specified operating environment and conditions**

**Product should be powered off and disconnected from the mains before any service or maintenance operation**

**Keep body parts, hair, clothing and jewelery away from moving parts in the product.**

**Do not operate the product without a lens installed**

**Use a lens plug when installing or moving the product**



**The unit is never to be operated if the unit is defective or the cover or seal is damaged.**



**No maintenance allowed by end user.**

**Do not open the cabinet. There are no user serviceable parts inside.**

**No service is allowed except by authorized personnel.**



**Service personnel should use effective laser safety goggles during service operations.**



**Use only the power cable provided.**



**Ensure that the power outlet includes a Ground connection, as this equipment MUST be earthed.**



**Take care to prevent small objects such as paper or wire from falling into the projector. If this does happen, switch off immediately, and have the objects removed by authorized service personnel.**



**Do not expose the projector to rain or moisture, and do not place any liquids on top of the projector.**

**Unplug before cleaning, and use a damp, not wet, cloth.**

**Do not touch the power plug with wet hands.**

**Do not touch the power plug during a thunder storm.**

**Handle the power cable carefully and avoid sharp bends. Do not use a damaged power cable.**



**Do not touch the ventilation outlets, as they will become hot in use.**

**Do not cover or obstruct the ventilation outlets or inlets.**

**Do not cover the lens whilst the projector is switched on. This could cause a fire.**

**Always allow the projector to cool for 5 minutes before disconnecting the power or moving the projector.**

**Never use strong detergents or solvents such as alcohol or thinners to clean the projector and lens.**

## Laser Safety Precautions



**Warning! Death or Serious Injury could occur if the following precautions are ignored**



**Permanent/Temporary Blindness Hazard**

**Do not look directly into the lens when the light source is on. The high brightness can cause permanent eye damage.**



**Caution – use of controls or adjustments or performance of procedures other than those specified herein may result in hazardous radiation exposure.**

**Do not attempt to operate the product without covers in place.**

**Lens Change should only be carried out by instructed and skilled persons in accordance with the Important Information document or User Manual. If in doubt consult your dealer.**

**Ensure the projector is switched off and AC power removed before attempting a lens change**



*This projector is a Laser Risk Group 2 product when a lens with a throw ratio less than 1.2: 1 is installed. It becomes Laser Risk Group 3 when a lens with a throw ratio greater than 1.2 :1 is installed.*



*Please note that the REF model is always classed under Laser Risk Group 2.*

## Laser Risk Group 2 Precautions



**Class 1 Laser Product, BS EN IEC 60825-1:2014.**

**Caution! As with any bright source, do not stare directly into beam, RG2 IEC 62471-5:2015.**

**The product should be installed and operated in accordance with the provisions of BS EN IEC 62471-5:2015 and the Important Information document or User Manual**

**Children should be supervised and never be allowed to stare into the projector beam at any distance from the projector.**

**Use caution when using a remote control to switch the projector on when standing in front of the projection lens.**

**Avoid the use of optical aids, such as binoculars or telescopes, inside the beam.**

**MOUNT ABOVE THE HEAD HEIGHT OF CHILDREN.** It is recommended to use a ceiling mount to place this product above the eyes of children.

## Laser Risk Group 3 Precautions



Not for household use.



**Class 1 Laser Product, BS EN IEC 60825-1:2014.**

**No direct exposure to the beam shall be permitted, RG3 BS EN IEC 62471-5:2015.**

**Operators shall control access to the beam within the hazard distance or install the product at a height that will prevent exposure of the spectator's eyes within the hazard distance. See Light Hazard Distance and Hazard Zone on page 35 for more information.**

**The product should be installed and operated in accordance with the provisions of BS EN IEC 62471-5:2015 and the Important Information document or User Manual by instructed and skilled persons only (BS EN IEC 62368-1:2020).**

## Laser Parameters

Wavelength (Red)	635-651 nm
Wavelength (Blue)	449-461 nm
Mode of operation	Pulsed, due to frame rate
Pulse duration (Red)	1.00 ms
Pulse duration (Blue)	0.76 ms
Pulse repetition rate	180 Hz
Maximum pulse energy (Red)	0.26 mJ
Maximum pulse energy (Blue)	0.15 mJ
Apparent source size	> 10 mm (at lens stop)
Divergence	> 100 mRad

## Light Output

The light output for the M-Vision 21000 II Series WUXGA projector is 21,000 Lumens at 100% laser power.

The light output for the M-Vision 24000 Series WUXGA projector is 24,000 Lumens at 100% laser power.

The light output for the M-Vision 27000 Series WUXGA projector is 27,000 Lumens at 100% laser power.

## Laser Power

The altitude and ambient temperature at the location where the projector is installed affects the laser power output. This is an automatic adjustment made by the projector:

Ambient temperature		Laser Power Output (%)		
		<4000ft (<1219m)	4000~8000ft (1219~2438m) High altitude mode	At 8000~13780ft (2438~4200m) High altitude mode
<26°C	<78.8°F	100%	90%	80%
26~32°C	78.8~89.6°F	100%	90%	80%
33~35°C	91.4~95°F	90%	80%	70%
36~40°C	96.8~104°F	80%	70%	60%
41~45°C	105.8~113°F	60%	60%	50%



*Laser power output is limited to 60% at 110VAC, with reduced light output.*



*High altitude mode is activated when the projector is installed at a location over 4000ft (1219m) above sea level.*

## Compliance with International Standards



### RF Interference

#### FCC

The Federal Communications Commission does not allow any modifications or changes to the unit EXCEPT those specified by Digital Projection in this manual. Failure to comply with this government regulation could void your right to operate this equipment.

This equipment has been tested and found to comply with the limits for a Class A digital device, pursuant with Part 15 of the FCC Rules. These limits are designed to provide reasonable protection against harmful interference when the equipment is operated in a commercial environment. This equipment generates, uses, and can radiate radio frequency energy and, if not installed and used in accordance with the instruction manual, may cause harmful interference to radio communications. Operation of this equipment in a residential area may cause harmful interference, in which case the user will be responsible for correcting any interference.

### Noise

#### GSGV Acoustic Noise Information Ordinance

The sound pressure level for the M-Vision 21000 II Series WUXGA is less than 46 dB (A) at normal operating mode according to ISO 3744 or ISO 7779.

The sound pressure level for the M-Vision 24000 Series WUXGA is less than 49 dB (A) at normal operating mode according to ISO 3744 or ISO 7779.

The sound pressure level for the M-Vision 27000 Series WUXGA is less than 50 dB (A) at normal operating mode according to ISO 3744 or ISO 7779.

### European Waste Electrical and Electronic Equipment (WEEE) Directive



Digital Projection Ltd is fully committed to minimizing Waste Electrical and Electronic Equipment. Our products are designed with reuse, recycling and recovery of all components in mind. To this end, at end of life, your projector may be returned to Digital Projection Ltd or its agent so that the environmental impact can be minimized.



# Product Labels

## Projector

# DIGITAL PROJECTION

**DLP PROJECTOR / DLP Projecteur ( 數位投影機 / 数字投影机 )**

Model / Modèle(型號 / 型号) :	<b>M-Vision 21000 WU II</b>
Part No. / Numéro de pièce (零部件号/零部件號) :	<b>123-536A</b>
Serial No. / Numéro de série. (序号/序號) :	 W012XXXXY0001
AC Input / Entrée CA(輸入 / 輸入) :	200-240 ~ 50/60Hz 10.6A 110-130 ~ 50/60Hz 11.1A

Caution : Do not open the cover. No user-serviceable parts inside  
 Avertissement : ne pas ouvrir le couvercle. Le produit ne contient aucune pièce interne réparable par l'utilisateur.  
 警告 : 請勿打開外殼, 設備內無服務性維修之元件  
 警告 : 請勿打开外壳, 设备内无服务性维修之元件

This device complies with part 15 of the FCC rules. CAN ICES-003(A) / NMB-003(A)  
 Operation is subject to the following two conditions:  
 (1) this device may not cause harmful interference, and  
 (2) this device must accept any interference received, including interference that may cause undesired operation.

警告 : 在居住环境中, 运行此设备可能会造成无线干扰。  
 警告 : 為避免電磁干擾, 本產品不應安裝或用於住宅環境。





334675900

This product is in conformity with performance standards for laser products under 21 CFR 1040, except with respect to those characteristics authorized by Variance Number 2021-V-0192 effective on March 20, 2021

<p>제품명 : 프로젝터          인증번호 : R-R-DVP-MV24000          ZU10002-23006          상호명/제조사 : 델타일렉트로닉스(주)          제조시기 : YYYY.MM.DD          제조공장/제조국가 : 델타 일렉트로닉스          (장수) 리미티드/중국          A/S 센터 : +82 2 515 5303          모델명 : M-Vision 21000 WU II</p> 	 C US   R41086 RoHS	<p>IS 13252 (Part 1)          IEC 60950-1            R-41213233          www.bis.gov.in          UK          CA</p>
--	---	--

**Delta Electronics (Jiangsu) Ltd.**  
 No.1688, Jiangxing East Rd.,  
 Wujiang Economic and Technological Development Zone,  
 Suzhou City, Jiangsu Province, P.R.C.215200  
 製造商 : Digital Projection Limited  
 Greenside Way Middleton Manchester, M24 1XX UK

M/F Date : January 2025  
 Made in China / Fabriqué en Chine  
 中国制造/中國製造



**M-Vision User Guides**

Follow link for Projector Documentation  
 Suivez le lien pour accéder à la documentation du projecteur  
 Produktdokumentation finden Sie unter dem Link  
 この二次元バーコードをスキャンしてプロジェクターのデータを取得してください  
 请扫描条码取得投影机文件  
 프로젝터 설명서를 보려면 링크를 방문하십시오

### M-Vision 21000 II Series WUXGA Manufacturers ID Label (EMEA and China)

## DIGITAL / PROJECTION



**DLP PROJECTOR / DLP Projecteur (數位投影機 / 数字投影机)**

Model / Modèle(型號 / 型号):	<b>M-Vision 21000 WU II</b>
Part No. / Numéro de pièce (零件号/零部件號):	<b>123-537A</b>
Serial No. / Numéro de série. (序号/序號):	 <small>*T312XXXXY0002*</small>
AC Input / Entrée CA(輸入 / 输入):	200-240 ~ 50/60Hz 10.6A 110-130 ~ 50/60Hz 11.1A

**Caution : Do not open the cover. No user-serviceable parts inside.**  
**Avertissement : ne pas ouvrir le couvercle. Le produit ne contient aucune pièce interne réparable par l'utilisateur.**  
**警告：請勿打開外殼，設備內無服務性維修之元件**  
**警告：請勿打開外殼，設備內無服務性維修之元件**

---

This device complies with part 15 of the FCC rules. CAN ICES-003(A) /NMB-003(A)  
 Operation is subject to the following two conditions:  
 (1) this device may not cause harmful interference, and  
 (2) this device must accept any interference received, including interference that may cause undesired operation.



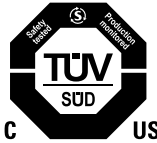

**警告：在居住环境中，运行此设备可能会造成无线干扰。**  
**警告：為避免電磁干擾，本產品不應安裝或使用於住宅環境。**

This product is in conformity with performance standards for laser products under 21 CFR 1040, except with respect to those characteristics authorized by Variance Number 2021-V-0192 effective on March 20, 2021



**C US**



**R41086  
RoHS**

**制造商：Digital Projection Limited**  
 Greenside Way Middleton Manchester, M24 1XX UK  
 M/F Date : April 2025  
 Made in Taiwan / Fabriqué en Taiwan / 台灣製造 / 台灣製造



**M-Vision User Guides**

Follow link for Projector Documentation  
 Suivre le lien pour accéder à la documentation du projecteur  
 Produktdokumentation finden Sie unter dem Link  
 この二次元バーコードをスキャンしてプロジェクターのデータを取得してください  
 请扫描条码获取投影机文件  
 프론트엔더 설명서를 보려면 링크를 방문하십시오

**M-Vision 21000 II Series WUXGA Manufacturers ID Label (USA TAA compliant)**

# DIGITAL / PROJECTION

**DLP PROJECTOR / DLP Projecteur (數位投影機 / 数字投影机)**

**Model / Modèle(型號 / 型号) : M-Vision 24000 WU**

**Part No. / Numéro de pièce (零件号/零件號) : 123-538A**

**Serial No. / Numéro de série. (序号/序號) :**



\*W312XXXCY0001\*

**AC Input / Entrée CA(輸入 / 輸入) : 200-240 ~ 50/60Hz 10.6A  
110-130 ~ 50/60Hz 11.1A**

**Caution : Do not open the cover. No user-serviceable parts inside**  
**Avertissement : ne pas ouvrir le couvercle. Le produit ne contient aucune pièce interne réparable par l'utilisateur.**

**警告：請勿打開外殼，設備內無服務性維修之元件**  
**警告：請勿打開外殼，設備內無服務性維修之元件**

---

This device complies with part 15 of the FCC rules. CAN ICES-003(A) /NMB-003(A)  
 Operation is subject to the following two conditions:  
 (1) this device may not cause harmful interference, and  
 (2) this device must accept any interference received, including interference that may cause undesired operation.

警告：在居住环境中，运行此设备可能会造成无线干扰。

警告：為避免電磁干擾，本產品不應安裝或使用於住宅環境。



This product is in conformity with performance standards for laser products under 21 CFR 1040, except with respect to those characteristics authorized by Variance Number 2021-V-0192 effective on March 20, 2021

제품명 : 프로젝터  
 인증번호 : R-R-DVP-MV24000  
 ZU10002-23006  
 상호명/제조사 : 델타일렉트로닉스(주)  
 제조시기 : YYYY,MM,DD  
 제조공장/제조국가 : 델타 일렉트로닉스 (강su) 리미티드/중국  
 A/S 센터 : +82 2 515 5303  
 모델명 : M-Vision 24000 WU



IS 13252 (Part 1)/  
IEC 60950-1

R-41213233  
www.bis.gov.in

UK  
CA

R41086  
RoHS

**Delta Electronics (Jiangsu) Ltd.**  
 No.1688, Jiangxing East Rd.,  
 Wujiang Economic and Technological Development Zone,  
 Suzhou City, Jiangsu Province, P.R.C.215200

**制造商 : Digital Projection Limited**  
 Greenside Way Middleton Manchester, M24 1XX UK

M/F Date : December 2024  
 Made in China /Fabriqué en Chine  
 中国制造/中國製造



**M-Vision User Guides**

Follow Link for Projector Documentation  
 Suivre le lien pour accéder à la documentation du projecteur  
 Produktdokumentation finden Sie unter dem Link  
 この二次元バーコードをスキャンしてプロジェクターのデータを取得してください  
 请扫描条形码取得投影机的文件  
 프로젝터 설명서를 보려면 링크를 방문하십시오

**M-Vision 24000 Series WUXGA Manufacturers ID Label (EMEA and China)**

# DIGITAL PROJECTION

**DLP PROJECTOR / DLP Projecteur (數位投影機 / 数字投影机)**

<b>Model / Modèle(型號 / 型号) :</b>	<b>M-Vision 24000 WU</b>
<b>Part No. / Numéro de pièce (零件号/零件號) :</b>	<b>123-539A</b>
<b>Serial No. / Numéro de série. (序号/序號) :</b>	 <small>T312XXXXY0002</small>
<b>AC Input / Entrée CA(輸入 / 輸入) :</b>	200-240 ~ 50/60Hz 10.6A 110-130 ~ 50/60Hz 11.1A

**Caution : Do not open the cover. No user-serviceable parts inside**  
**Avertissement : ne pas ouvrir le couvercle. Le produit ne contient aucune pièce interne réparable par l'utilisateur.**

**警告 : 請勿打開外殼, 設備內無服務性維修之元件**  
**警告 : 請勿打開外殼, 設備內無服務性維修之元件**

This device complies with part 15 of the FCC rules. CAN ICES-003(A) /NMB-003(A)  
 Operation is subject to the following two conditions:  
 (1) this device may not cause harmful interference, and  
 (2) this device must accept any interference received, including interference that may cause undesired operation.

**警告 : 在居住环境中, 运行此设备可能会造成无线干扰。**  
**警告 : 為避免電磁干擾, 本產品不應安裝或使用於住宅環境。**





This product is in conformity with performance standards for laser products under 21 CFR 1040, except with respect to those characteristics authorized by Variance Number 2021-V-0192 effective on March 20, 2021



**C US**



**R41086  
RoHS**

**制造商 : Digital Projection Limited**  
 Greenside Way Middleton Manchester, M24 1XX UK

M/F Date : March 2026  
 Made in Taiwan / Fabriqué en Taïwan / 台灣製造 / 台灣製造



**M-Vision User Guides**

Follow link for Projector Documentation  
 Suivre le lien pour accéder à la documentation du projecteur  
 Produktdokumentation finden Sie unter dem Link  
 この二次元バーコードをスキャンしてプロジェクターのデータを取得してください  
 请扫描条码来获取投影机的文件  
 프론트버더 설명서를 보려면 링크를 방문하십시오

**M-Vision 24000 Series WUXGA Manufacturers ID Label (USA TAA compliant)**

# DIGITAL PROJECTION

**DLP PROJECTOR / DLP Projecteur (數位投影機 / 数字投影机)**

<b>Model / Modèle(型號 / 型号) :</b>	<b>M-Vision 27000 WU</b>
<b>Part No. / Numéro de pièce (零部件号/零件號) :</b>	<b>123-540A</b>
<b>Serial No. / Numéro de série. (序号/序號) :</b>	 <small>*W312XXXCY0001*</small>
<b>AC Input / Entrée CA(輸入 / 输入) :</b>	200-240 ~ 50/60Hz 10.6A 110-130 ~ 50/60Hz 11.1A

**Caution : Do not open the cover. No user-serviceable parts inside.**  
**Avertissement : ne pas ouvrir le couvercle. Le produit ne contient aucune pièce interne réparable par l'utilisateur.**  
**警告：請勿打開外殼，設備內無服務性維修之元件。**  
**警告：請勿打開外殼，設備內無服務性維修之元件。**

---

This device complies with part 15 of the FCC rules. CAN ICES-003(A) /NMB-003(A)  
 Operation is subject to the following two conditions:  
 (1) this device may not cause harmful interference, and  
 (2) this device must accept any interference received, including interference that may cause undesired operation.



**警告：在居住環境中，運行此設備可能會造成無線干擾。**  
**警告：為避免電磁干擾，本產品不應安裝或用於住宅環境。**



38467300

This product is in conformity with performance standards for laser products under 21 CFR 1040, except with respect to those characteristics authorized by Variance Number 2021-V-0192 effective on March 20, 2021

제품명 : 프로젝터 인증번호 : R-R-DVP-MV27000 ZU10002-23004 상호명/제조사 : 델타일렉트로닉스(주) 제조시기 : YYYY,MM,DD 제조공장/제조국가 : 델타 일렉트로닉스 (광주) 리미티드/중국 A/S 센터 : +82 2 515 5303 모델명 : M-Vision 27000 WU	 C US    R41086 RoHS	IS 13252 (Part 1)/ IEC 60950-1  R-41213233 www.bis.gov.in UK CA
---	--	--

**Delta Electronics (Jiangsu) Ltd.**  
 No.1688, Jiangxing East Rd.,  
 Wujiang Economic and Technological Development Zone,  
 Suzhou City, Jiangsu Province, P.R.C.215200  
**制造商 : Digital Projection Limited**  
 Greenside Way Middleton Manchester, M24 1XX UK

M/F Date : November 2023  
 Made in China /Fabriqué en China  
 中国製造/中國製造



**M-Vision User Guides**

Follow link for Projector Documentation  
 Suivre le lien pour accéder à la documentation du projecteur  
 Produktdokumentation finden Sie unter dem Link  
 この二次元バーコードをスキャンしてプロジェクターのデータを取得してください  
 请扫描条形码取得投影机的文件  
 프로젝트 설명서를 보려면 링크를 방문하십시오

**M-Vision 27000 Series WUXGA Manufacturers ID Label (EMEA and China)**

## DIGITAL PROJECTION

**DLP PROJECTOR / DLP Projecteur (數位投影機 / 数字投影机)**

<p><b>Model / Modèle(型號 / 型号) :</b></p> <p><b>Part No. / Numéro de pièce (零部件号/零部件號) :</b></p> <p><b>Serial No. / Numéro de série. (序号/序號) :</b></p> <p><b>AC Input / Entrée CA(輸入 / 输入) :</b></p>	<p style="text-align: center;"><b>M-Vision 27000 WU</b></p> <p style="text-align: center;"><b>123-541A</b></p> <p style="text-align: center; font-size: small;">T312XXXXY0002</p> <p>200-240 ~ 50/60Hz 10.6A 110-130 ~ 50/60Hz 11.1A</p>
--	--

**Caution : Do not open the cover. No user-serviceable parts inside.**  
**Avertissement : ne pas ouvrir le couvercle. Le produit ne contient aucune pièce interne réparable par l'utilisateur.**  
**警告 : 請勿打開外殼,設備內無服務性維修之元件**  
**警告 : 請勿打開外殼,設備內無服務性維修之元件**

---

This device complies with part 15 of the FCC rules. CAN ICES-003(A) / NMB-003(A)  
 Operation is subject to the following two conditions:  
 (1) this device may not cause harmful interference, and  
 (2) this device must accept any interference received, including interference that may cause undesired operation.

**警告 : 在居住环境中, 运行此设备可能会造成无线干扰。**  
**警告 : 為避免電磁干擾, 本產品不應安裝或用於住宅環境。**

This product is in conformity with performance standards for laser products under 21 CFR 1040, except with respect to those characteristics authorized by Variance Number 2021-V-0192 effective on March 20, 2021

**C US**

**R41086**  
**RoHS**

**制造商 : Digital Projection Limited**  
 Greenside Way Middleton Manchester, M24 1XX UK  
 M/F Date : February 2024  
 Made in Taiwan / Fabriqué en Taiwan / 台灣製造 / 台灣製造

**M-Vision User Guides**

Follow link for Projector Documentation  
 Suivre le lien pour accéder à la documentation du projecteur  
 Produktdokumentation finden Sie unter dem Link  
 この二次元バーコードをスキャンしてプロジェクターのデータを取得してください  
 请扫描条码获取投影机的文件  
 프론트엔더 설명서를 보려면 링크를 방문하십시오

**M-Vision 27000 Series WUXGA Manufacturers ID Label (USA TAA compliant)**

**CLASS 1 / RG3 Laser Product**  
Warning! Do not look into the beam.  
No direct exposure to beam is permitted.  
CLASS 1 BS EN IEC 60825-1:2014  
RG3 BS EN IEC 62471-1:2015  
Hazard Distance. Refer to Manual  
Not for Household Use

**CLASSE 1 / RG3 Laser Product**  
Attention! Ne pas regarder dans le faisceau.  
Pas d'exposition directe faisceau est autorisée.  
CLASS 1 BS EN IEC 60825-1:2014  
RG3 BS EN IEC 62471-1:2015  
Distance de danger. Se reporter au manuel  
Pas à usage domestique

**CLASS 1 / RG3 雷射產品**  
警告！請勿直視雷射光束  
不允許直接觀看雷射光束  
第 1 類 BS EN IEC 60825-1:2014  
RG3 BS EN IEC 62471-1:2015  
危險距離。參閱使用手冊  
不適合家庭使用

**CLASS 1 / RG3 雷射產品**  
警告！不要直視雷射光束  
不允許直接觀看雷射光束  
第 1 類 BS EN IEC 60825-1:2014  
RG3 BS EN IEC 62471-1:2015  
危險距離。參閱使用手冊  
不適合家庭使用

**LENS CHANGE / 鏡頭更換 / 鏡頭更換**  
Refer the manual / 請參閱手冊 / 請參閱手冊

**Complies with FDA performance standards for laser products except for deviation pursuant to Laser Notice No. 57, dated May 8, 2019.**

**RG2**  
This projector employing RG2 lens complies with FDA performance standards for laser products except for conformance as a Risk Group 2 LP as defined in IEC 62471-1: Ed. 1.0. For more information see Laser Notice No. 57, dated May 8, 2019.

**RG3**  
Warning! No direct exposure to the beam is permitted. Not for household use.  
This projector employing RG3 lens complies with performance standards for laser product 21 CFR Part 1040 except with respect to those characteristics authorized by Variance Number 2021-4-4192 effective on March 20, 2021

**CAUTION! Do not stare into the beam**

**RG2**  
This projector may become RG3 when an interchangeable lens with throw ratio greater than 1.2 is installed. Refer to the manual for the lens kit and hazard distance before operation.  
Such combinations of projector and lens are intended for professional use only, and are not intended for consumer use.

**LASER APERTURE**  
雷射雷射之孔徑  
激光雷射窗口  
OUVERTURE LASER

**DO NOT let a laser beam directly enter the projector lens.**

**WARNING - MOUNT ABOVE THE HEADS OF CHILDREN!**  
Do not look into the beam less than 1m.  
No direct eye exposure to the beam is permitted.  
"AVERTISSEMENT-INSTALLER AU-DESSUS DE LA TÊTE DES ENFANTS."  
Avertissement supplémentaire contre l'exposition oculaire pour des expositions à une distance de moins de 1m.

**Risk Group 3 Explanatory Label**

**Label Locations**

1. Location of the Explanatory Label with Certification Statement, Risk Statement, Hazard Warning, Laser Aperture Warning and Lens Safety Warning on the top of the projector.
2. Location of the Manufacturer's ID Label with User Guides Label on the right side of the projector.

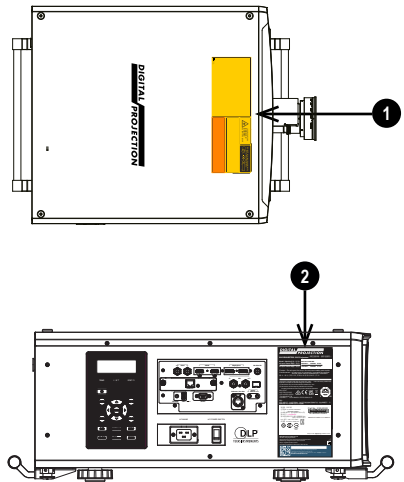

# Projector - REF Model



**DLP PROJECTOR / DLP Projecteur (數位投影機 / 数字投影机)**

<b>Model / Modèle(型號 / 型号) :</b>	<b>M-Vision 21000 WU REF</b>
<b>Part No. / Numéro de pièce (零件号/零件號) :</b>	<b>124-077A</b>
<b>Serial No. / Numéro de série. (序号/序號) :</b>	 <small>*T312XXXXY0002*</small>
<b>AC Input / Entrée CA(輸入 / 輸入) :</b>	200-240 ~ 50/60Hz 10.6A 110-130 ~ 50/60Hz 11.1A

Caution : Do not open the cover. No user-serviceable parts inside  
 Avertissement : ne pas ouvrir le couvercle. Le produit ne contient aucune pièce interne réparable par l'utilisateur.  
 警告 : 請勿打開外殼,設備內無服務性維修之元件  
 警告 : 請勿打開外殼,設備內無服務性維修之元件

This device complies with part 15 of the FCC rules. CAN ICES-003(A) /NMB-003(A)  
 Operation is subject to the following two conditions:  
 (1) this device may not cause harmful interference, and  
 (2) this device must accept any interference received, including interference that may cause undesired operation.

警告 : 在居住环境中,运行此设备可能会造成无线干扰。  
 警告 : 為避免電磁干擾,本產品不應安裝或用於住宅環境。



製造商 : Digital Projection Limited  
 Greenside Way Middleton Manchester, M24 1XX UK  
 M/F Date : August 2024  
 Made in Taiwan / Fabriqué en Taiwan / 台灣製造 / 台灣製造

**M-Vision User Guides**

Follow link for Projector Documentation  
 Suivre le lien pour accéder à la documentation du projecteur  
 Produktedokumentation finden Sie unter dem Link  
 このリンクからコードをダウンロードしてプロジェクターのデータを取得してください  
 請掃描條碼來取得投影機的文件  
 프로젝트 설명서를 보려면 링크를 클릭하십시오

## M-Vision 21000 II Series WUXGA Manufacturers ID Label (USA TAA compliant - REF)



## DIGITAL PROJECTION

**DLP PROJECTOR / DLP Projecteur (數位投影機 / 数字投影机)**

<p><b>Model / Modèle(型號 / 型号) :</b></p> <p><b>Part No. / Numéro de pièce (零部件号/零部件號) :</b></p> <p><b>Serial No. / Numéro de série. (序号/序號) :</b></p> <p><b>AC Input / Entrée CA(輸入 / 輸入) :</b></p>	<p><b>M-Vision 24000 WU REF</b></p> <p><b>124-078A</b></p>  <p style="font-size: 8px;">T312XXXXY0002</p> <p>200-240 ~ 50/60Hz 10.6A</p> <p>110-130 ~ 50/60Hz 11.1A</p>
--	---

**Caution : Do not open the cover. No user-serviceable parts inside.**  
**Avertissement : ne pas ouvrir le couvercle. Le produit ne contient aucune pièce interne réparable par l'utilisateur.**  
**警告：請勿打開外殼，設備內無服務性維修之元件。**  
**警告：請勿打开外壳，设备内无服务性维修之元件。**

---

This device complies with part 15 of the FCC rules. CAN ICES-003(A) /NMB-003(A)  
 Operation is subject to the following two conditions:  
 (1) this device may not cause harmful interference, and  
 (2) this device must accept any interference received, including interference that may cause undesired operation.



**警告：在居住环境中，运行此设备可能会造成无线干扰。**  
**警告：為避免電磁干擾，本產品不應安裝或用於住宅環境。**



**C US**



**R41086  
RoHS**

**制造商：Digital Projection Limited**  
 Greenside Way Middleton Manchester, M24 1XX UK  
 M/F Date : July 2025  
 Made in Taiwan / Fabriqué en Taiwan / 台灣製造 / 台灣製造



**M-Vision User Guides**

**Follow link for Projector Documentation**  
 Suivre le lien pour accéder à la documentation du projecteur  
 Produktdokumentation finden Sie unter dem Link  
 この二次元バーコードをスキャンしてプロジェクターのデータを取得してください  
 请扫描条形码来获取投影机的文件  
 프로그램어 설명서를 보려면 링크를 방문하십시오

**M-Vision 21000 II Series WUXGA Manufacturers ID Label (USA TAA compliant - REF)**

## DIGITAL / PROJECTION

**DLP PROJECTOR / DLP Projecteur (數位投影機 / 数字投影机)**

<p><b>Model / Modèle(型號 / 型号) :</b></p> <p><b>Part No. / Numéro de pièce (零部件号/零部件號) :</b></p> <p><b>Serial No. / Numéro de série. (序号/序號) :</b></p> <p><b>AC Input / Entrée CA(輸入 / 輸入) :</b></p>	<p style="text-align: center;"><b>M-Vision 27000 WU REF</b></p> <p style="text-align: center;"><b>124-079A</b></p> <p style="text-align: center; font-size: small;">T312XXXXY0002</p> <p style="text-align: center;">200-240 ~ 50/60Hz 10.6A</p> <p style="text-align: center;">110-130 ~ 50/60Hz 11.1A</p>
--	---

**Caution ; Do not open the cover. No user-serviceable parts inside**  
**Avertissement : ne pas ouvrir le couvercle. Le produit ne contient aucune pièce interne réparable par l'utilisateur.**  
**警告 : 請勿打開外殼,設備內無服務性維修之元件**  
**警告 : 請勿打開外殼,設備內無服務性維修之元件**

---

This device complies with part 15 of the FCC rules. CAN ICES-003(A) /NMB-003(A)  
 Operation is subject to the following two conditions:  
 (1) this device may not cause harmful interference, and  
 (2) this device must accept any interference received, including interference that may cause undesired operation.

**警告 : 在居住环境中, 运行此设备可能会造成无线干扰。**  
**警告 : 為避免電磁干擾, 本產品不應安裝或用於住宅環境。**

**C US**

**R41086**  
**RoHS**

**制造商 : Digital Projection Limited**  
 Greenside Way Middleton Manchester, M24 1XX UK  
 M/F Date : May 2026  
 Made in Taiwan / Fabriqué en Taïwan / 台灣製造 / 台灣製造

**M-Vision User Guides**

Follow link for Projector Documentation

Suivre le lien pour accéder à la documentation du projecteur

Produkttdokumentation finden Sie unter dem Link

この二次元バーコードをスキャンしてプロジェクターのデータを取得してください

請扫描条码取得投影机的文件

프론트엔더 설명서를 보려면 링크를 방문하십시오

**M-Vision 21000 II Series WUXGA Manufacturers ID Label (USA TAA compliant - REF)**

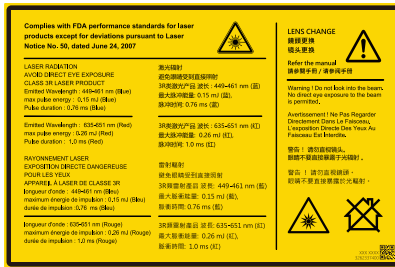

**Explanatory Label**



**Laser Aperture and Lens Safety Label**

**Label Locations - REF Model**

1. Location of the Laser Aperture and Lens Safety Label on the top of the projector.
2. Location of the Explanatory Label with Certification Statement on the top of the projector.
3. Location of the Manufacturer's ID Label with User Guides Label on the right side of the projector.

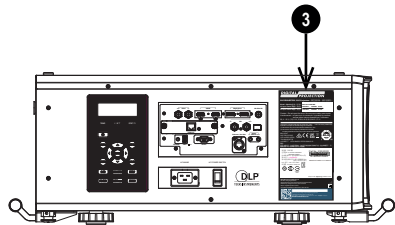
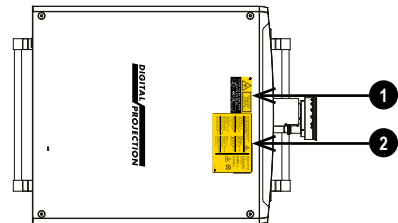

## Location of Laser Aperture

1. The laser aperture is located as indicated below.



**Do not look directly at the light coming from the lens.**

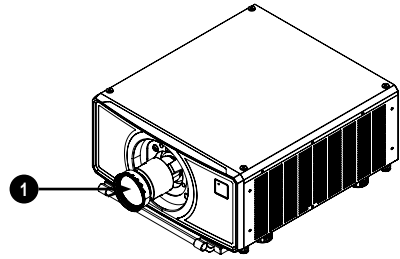

## Interlock Switches

Interlock switches are installed inside the projector. These will power-off the system when activated.

1. Will be activated when the projection lens is removed or misplaced.
2. Will be activated when the top cover is removed.

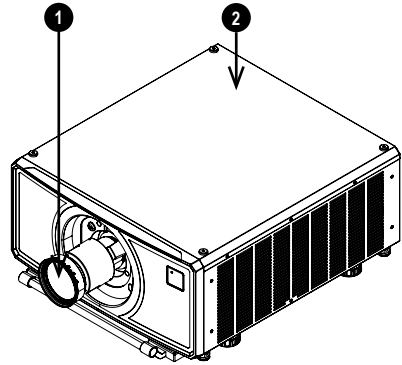

## Installation Precautions



**The projector must be installed only by suitably qualified personnel, in accordance with local building codes.**

**The projector is heavy. Use safe handling techniques when lifting the projector.**

**Do not drop or knock the projector.**

**Do not install the projector close to anything that might be affected by its operational heat, for instance, polystyrene ceiling tiles, curtains etc. Place the projector in a dry area away from sources of dust, moisture, steam, smoke, sunlight or heat.**

**Ensure that the intake vents do not recycle hot air from the exhaust vent. When operating the projector in an enclosed space, ensure that the surrounding air temperature within the enclosure does not exceed operation temperature while the projector is running, and the air intake and exhaust vents are unobstructed.**

**All enclosures should pass a certified thermal evaluation to ensure that the projector does not recycle exhaust air, as this may cause the device to shutdown even if the enclosure temperature is with the acceptable operation temperature range.**

**Avoid installing at high temperature, insufficient cooling and heavy dust locations.**

**Keep your product away from fluorescent lamps (>1 Meter) to avoid malfunction caused by IR interference.**

**Avoid installing near an air conditioner duct or a subwoofer.**

**The projector should be installed as close to the power outlet as possible.**

**The power connection should be easily accessible, so that it can be disconnected in an emergency.**

**Please pay attention to projector installation with respect to other staging laser light equipment set-up. These systems can cause permanent damage to the DMD™ imaging devices used in our projectors. This damage is not covered by our warranty.**

When using projectors in environments with third party high power laser systems avoid direct laser beams pointing towards the projection lens. This may cause incident light to converge into the optical engine and cause damage to the DLP™ DMD™.



Before installation, make sure that the surface, ceiling or rigging that is to support the projector is capable of supporting the combined weight of the projector and lens.

Backup safety chains or wires should always be used with ceiling mount installations.

When installing a ceiling mount, make sure the weight limit is not exceeded and the projector is firmly secured.

When stacking projectors, the stack **MUST** be vertical, to ensure that the stresses are distributed to all four chassis corners.

Do not stack more than 2 projectors.

The projector can be operated any position, as shown in the diagram:

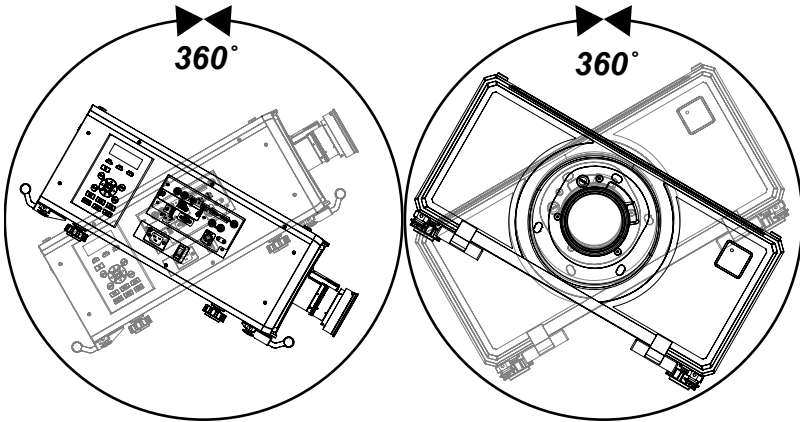

*Tilt (Left) and Roll (Right)*



The following positions are to be avoided as they can reduce motor life:

Lens facing down

Inputs and outputs facing up

Allow at least 50cm (19.7in) of space between the ventilation outlets and any wall, and 30cm (11.8in) on all other sides.

Minimum 500mm  
(19.69in)

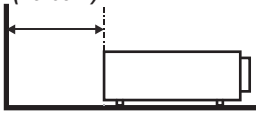

Minimum 500mm  
(19.69in)

Minimum 500mm  
(19.69in)

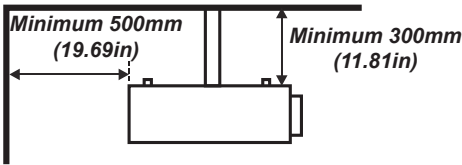
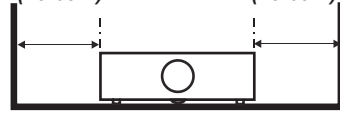

**Example Positioning**





**Make sure the lens cap is removed from the lens before operating the projector. Light energy levels have been known to cause damage to both the lens and projector optics. This damage is not covered by our warranty.**

**Make sure the lens cap is removed from the rear of the lens before it is inserted into the projector.**

**Connect the LAN cable only to a computer LAN connection. Other similar connectors may have a dangerously high voltage source.**

**The power cord and signal cable should be connected before the projector is powered on. During startup and operation, DO NOT insert or remove the signal cable or the power cord to avoid damaging the projector.**

**Turn on High Altitude Mode when located in high altitude areas.**



**The projector generates heat during use. The internal fans dissipate the heat of the projector when shutting down, which could continue for a certain period. After the projector enters STANDBY MODE, remove the power cord. DO NOT remove the power cord during shutdown as it may cause damage to the projector and may affect the service life of the projector.**

**Do not place heavy objects on top of the projector chassis. Only the chassis corners and the optional rigging frame are capable of withstanding the weight of another projector.**

## Laser Hazard Installation Precautions



**Do not attempt to access the internal hardware of the projector. Do not attempt to modify or remove the laser module.**

**Do not operate the projector without its protective covers.**

**Please consult with a qualified professional to install or remove the lens.**



*This projector is a Laser Risk Group 2 product when a lens with a throw ratio less than 1.2: 1 is installed. It becomes Laser Risk Group 3 when a lens with a throw ratio greater than 1.2 :1 is installed.*



*Please note that the REF model is always classed under Laser Risk Group 2.*

### Laser Risk Group 2 Installation



**This product is a Class 1 Risk Group 2 laser product. It must be installed in a safe place.**

**The product should be installed and operated in accordance with the provisions of BS EN IEC 62471-5:2015 and the Important Information document or User Manual**

**Do not operate the projector without a lens installed.**

**MOUNT ABOVE THE HEAD HEIGHT OF CHILDREN.** It is recommended to use a ceiling mount to place this product above the eyes of children.

### Laser Risk Group 3 Installation Precautions



**This product is a Class 1 Risk Group 3 laser product. It must be installed in a safe place and must be handled by qualified and professionally trained personnel.**

**Operators shall control access to the beam within the hazard distance or install the product at a height that will prevent exposure of the spectator's eyes within the hazard distance.**

**The product should be installed and operated in accordance with the provisions of BS EN IEC 62471-5:2015 and the Important Information document or User Manual by instructed and skilled persons only (BS EN IEC 62368-1:2020).**

## Light Hazard Warning



No direct exposure to the beam is permitted, RG3 BS EN IEC 62471-5:2015.

## Light Hazard Distance and Hazard Zone



**Hazard Distances for Laser Risk Group 3 variants. Operators should control access to the beam within the hazard distance or install the projector at sufficient height to prevent exposures of spectators' eyes within the hazard area.**

**When the projector is installed overhead, allow a minimum of 3m between the floor surface and the Light Hazard Zone.**

The hazard distance is the distance measured from the projection lens at which the intensity or energy per unit of surface is lower than the applicable exposure limit on the cornea or skin. ①

The hazard zone is the area from the projection lens up to the hazard distance that encompasses where the projected beam is considered hazardous. ②

If the person is within the hazard zone, the beam is considered unsafe for exposure.

The hazard distance for this projector is related to the fitted lens:

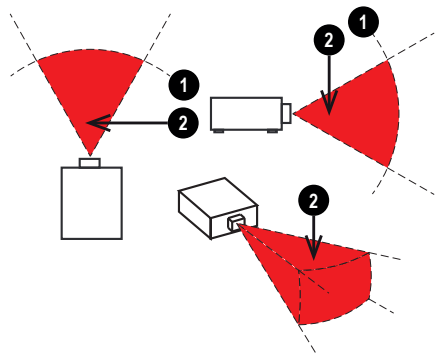

Lens	Hazard Distance
0.38 : 1	0m
0.90 - 1.20 : 1 zoom	0m
1.20 - 1.56 : 1 zoom	2.16m
1.50 - 2.00 : 1 zoom	3.52m
2.00 - 4.00 : 1 zoom	4.00m
4.00 - 7.00 : 1 zoom	5.20m
6.90 - 10.30 : 1 zoom	8.00m

### Restriction Zone

A restriction zone should be in place around the hazard zone to prevent any person from entering the hazard zone with any part of their body:

- Horizontal clearance **1**. This should be no less than 2.5m around the hazard zone **2**.
- Vertical clearance **3**. This should be no less than 3m between the hazard zone **2** and the floor when the projector is installed overhead.

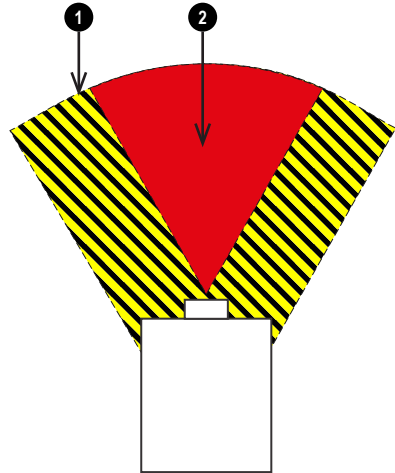

**Hazard Zones - Horizontal Clearance (Top View)**

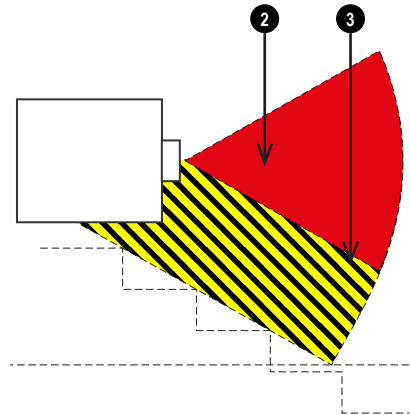

**Hazard Zones - Vertical Clearance (Side View)**

## Fitting a lens



**The projector must be fully turned off prior to attempting a lens change.**



**When changing the lens, avoid using excessive force as this may damage the equipment.**

**Avoid touching the surface of the lens as this may result in image impairment.**



*The lens is shipped separately.*



*Take care to preserve the original lens packaging and protective caps for future use.*



*The projector will not power on without the lens fitted.*

The following lenses are available for this projector:

Lens Throw ratio	M-Vision 21000 II Series WUXGA M-Vision 24000 Series WUXGA M-Vision 27000 Series WUXGA		
	(EMEA and China)	(USA TAA compliant)	(USA TAA compliant - REF)
0.38 : 1	✓	✓	✓
0.90 - 1.20 : 1 zoom	✓	✓	✓
1.20 - 1.56 : 1 zoom	✓	✓	✓
1.50 - 2.00 : 1 zoom	✓	✓	✓
2.00 - 4.00 : 1 zoom	✓	✓	✓
4.00 - 7.00 : 1 zoom	✓	✓	N/A
6.90 - 10.30 : 1 zoom	✓	✓	N/A



*Please refer to the user manual for details about each lens.*

## Inserting a new lens

1. Remove the front and rear lens caps

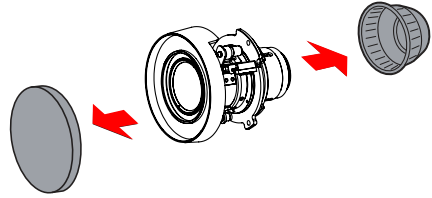

2. Insert the lens with the connector in upright position.

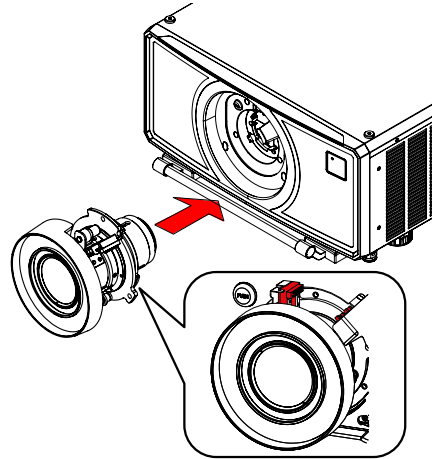

3. Rotate the lens clockwise until it clicks into place.

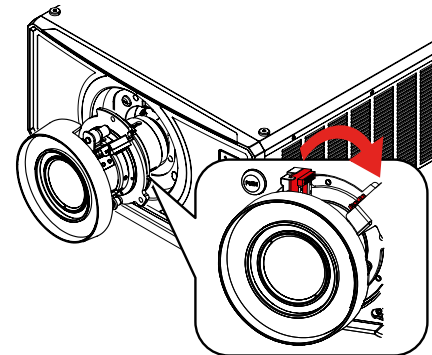

## Removing the lens

1. Push the lens release button all the way in
2. Turn the lens anti-clockwise until it disengages
3. Slowly remove the lens
4. Fit lens caps to the front and rear of the lens
5. Fit a lens aperture cap or a new lens to the projector. See Inserting a new lens on the previous page for guidance on inserting a lens.

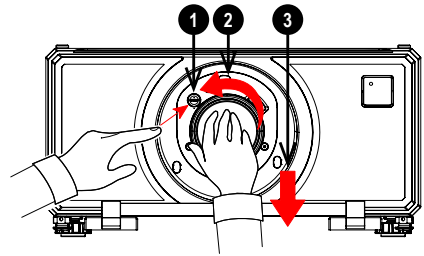

## Positioning the screen and projector

1. Install the screen, ensuring that it is in the best position for viewing by your audience.
2. Mount the projector, ensuring that it is at a suitable distance from the screen for the image to fill the screen.

The drawing shows the positions of the mounting points:

- **Four adjustable feet for tabletop mount ①.**

Set the adjustable feet so that the projector is level, and perpendicular to the screen.

- **Six M6 holes for ceiling mount ②.**

The mounting screws should not penetrate more than 15 mm into the body of the projector.

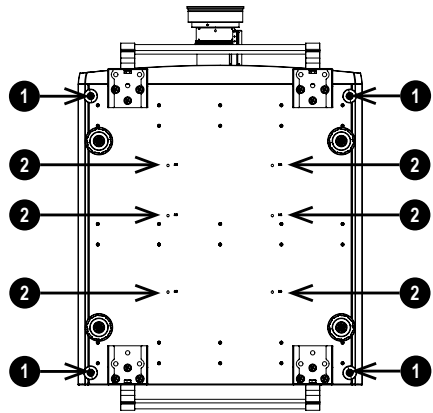

*Projector Bottom*



**Do not use the threaded holes for the adjustable feet to hang or mount the projector.**



## Stacking



The projectors must be in a vertical position when they are stacked. This will ensure that the stresses are distributed to all four corners of the chassis.

Do not use the threaded holes for the adjustable feet to hang or mount the projector.

Do not use the carry handles to hang or mount the projector.

Do not stack more than 2 projectors.

Use only the provided screws with a torque of 25-30 kgf cm (2.45 - 2.94 Nm).

It is the customer's responsibility to ensure that the assembly is carried out securely.

### Pin and cup stacking

1. Remove the four screws on the top side of the projector that will be on the bottom of the stack.

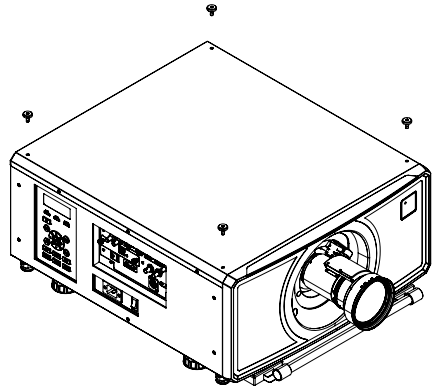

2. Insert and secure the stacking tops in place of the removed screws.

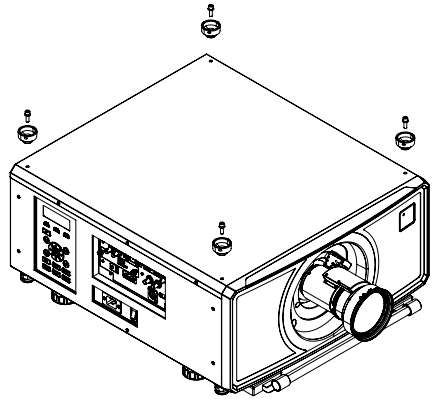

3. Mount the top projector onto the bottom projector. Ensure that all four pins are placed into the cups on the bottom projector.

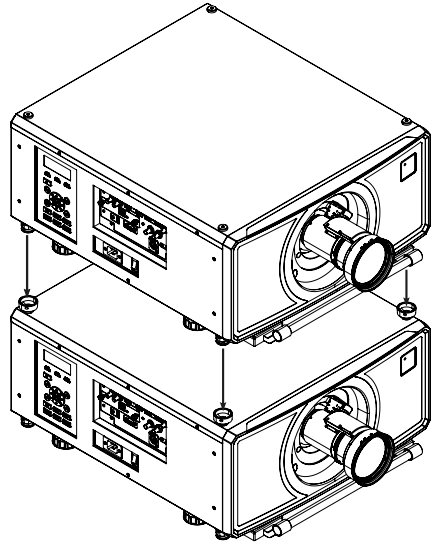

4. Use the stacking safety pins to secure each connection.

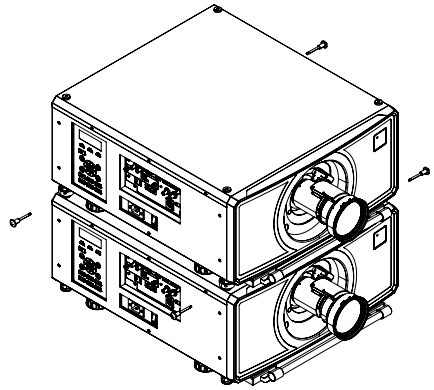

## Signal connections

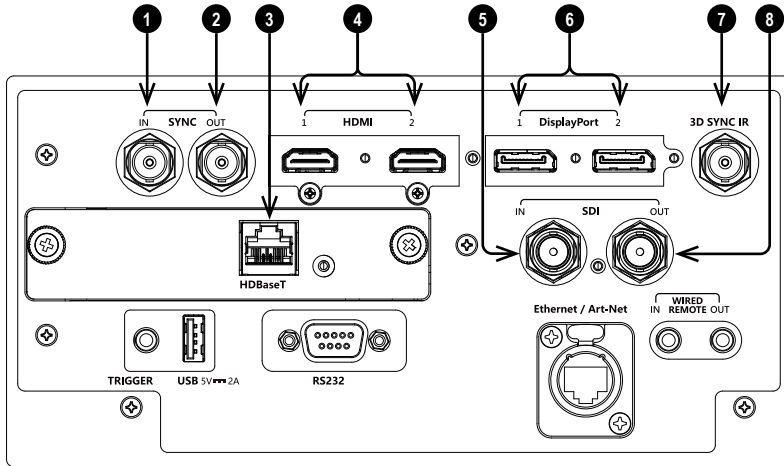

1. **Sync In**  
3D sync input signal. Use a BNC connector to connect the 3D sync from your graphics card or server.
2. **Sync Out**  
3D sync output signal. This enables synchronized 3D with multiple projectors. Use a 3-pin DIN connector to connect this to another projector.
3. **HDBaseT (Optional board)**  
Receives digital signal from HDBaseT-compliant devices. Cat 6A cable is recommended.
4. **HDMI 1 / HDMI 2**  
HDMI 2.0 inputs supporting HDCP 2.2 and **Frame Sequential, Top and Bottom, Side By Side** and **Frame packing** 3D formats. Connect an **HDMI** cable to the connector.
5. **SDI in**  
SDI input supporting up to 12G-SDI. Connect an SDI cable to the connector.
6. **DisplayPort 1 / DisplayPort 2**  
Display Port 1.2 input. Connect a Display Port cable to the connector.
7. **3D Sync IR**  
Sync output signal. Connect this to an IR emitter or ZScreen.
8. **SDI out**  
SDI output supporting up to 12G-SDI. Connect an SDI cable to distribute the SDI signal to another projector.



*Please refer to the user manual for further details about input signals that require multiple connection ports.*

## Control connections

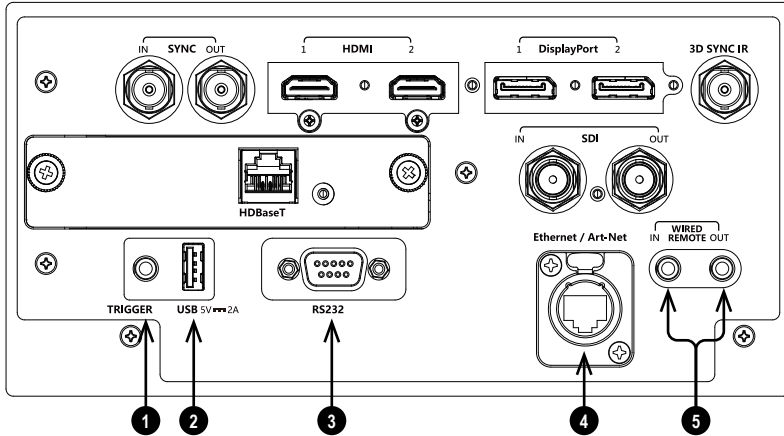

### 1. Trigger

The trigger output can be used to control an electrically operated screen. The screen will be automatically deployed when the projector starts up and retracted when the projector shuts down.

### 2. USB

USB 5V / 2A output. Connect a USB cable to supply power to an external device.

### 3. RS232

All of the projector's features can be controlled via a serial connection, using commands described in the **Protocol Guide**. Use a crossover cable to connect directly to a computer.

### 4. Ethernet/Art-Net

#### • Ethernet

The projector's features can be controlled via a LAN connection. For example using Digital Projection's Projector Controller application, a terminal-emulation program or PJ-Link.

#### • Art-Net

Art-Net compatible RJ45 etherCON input. Connect an etherCON connector cable from an Ethernet LAN/WLAN network to receive DMX-512 data over an IP-based network.

### 5. Wired Remote

The remote control can be connected using a standard 3.5 mm mini jack cable (tip-ring-sleeve, or TRS).

## AC Power Precautions



**Warning! Death or Serious Injury could occur if the following precautions are ignored**

**Shock Hazard! Only use the AC power cord provided or recommended by the manufacturer**

**Fire & Shock Hazard! Do not operate the product unless the power cord, socket and plug meet local rating standards**

**Do not attempt operation if the AC supply is not within the specified parameters**

**The AC power cord must be inserted into a socket with grounding**

**Disconnect the product from the AC supply before installing, moving, servicing, cleaning or removing covers**

**Do not use an AC power cord that appears damaged**

**Do not overload power sockets or extension cords**

**The projector can operate at 110V or 200V. Voltage selection is automatic. Power off the projector before switching power outlets.**

### Connecting the power supply

1. Firmly push the mains connector into the AC socket **1**

When the cable is plugged in and the power supply is on, the projector is OFF until the power button is switched to ON.

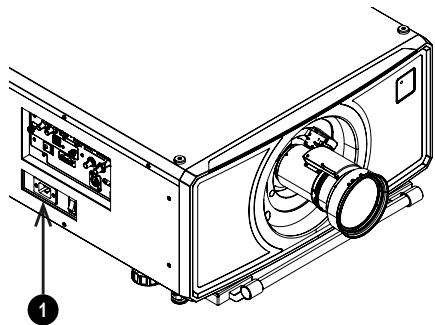

**Use only the power cable provided.**

**Ensure that the power outlet includes a ground connection as this equipment MUST be earthed.**

**Handle the power cable carefully and avoid sharp bends. Do not use a damaged power cable.**

## Basic Operating Instructions



See Control panel on page 52 for guidance on using the control panel to control the projector.



See Remote control on page 55 for guidance on using the remote control to control the projector.

### Switching the projector on

1. Make sure a lens is fitted. Connect the power cable between the mains supply and the projector.
2. Switch on at the switch next to the power connector.  
The **POWER** indicator lights red to signal that the projector is in STANDBY mode.
3. Press one of the following buttons:
  - On the remote control, the **ON** button
  - On the projector control panel, the **POWER** button.

The **POWER** indicator begins flashing green and the fans start working. When the flashing stops and the **POWER** and **LIGHT** indicators both light steady green, the projector is switched on.

### Switching the projector off

1. Press **OFF** on the remote control or **POWER** on the control panel, then press again to confirm your choice.  
The **POWER** indicator on the control panel will start flashing amber, the system will go out and the cooling fans will run for a short time until the **POWER** indicator goes steady red to indicate that the projector has entered STANDBY mode.
2. If you need to switch the projector off completely, switch off at the mains power switch next to the power connector and then disconnect the power cable from the projector.

### Interlock reset

In the event of the laser illumination turning off as a result of an Interlock break:

1. Make sure all interlocks are in place. See Interlock Switches on page 29
2. Turn ON the laser illumination. See Switching the projector on above



## Selecting an input signal

1. Connect one or more image sources to the projector.
2. Select the input you want to display:
  - Press one of the input buttons on the remote control or control panel.
  - Alternatively, open the On-screen display (OSD) by pressing **MENU**. Highlight **Input** from the main menu, press **ENTER/OK** and then select an input signal using the **UP** and **DOWN** arrow buttons. Press **ENTER/OK** to confirm your choice.

## Selecting a test pattern

The following test patterns are available: Off, White, Black, Red, Green, Blue, Checkerboard, Crosshatch, Color Bar, Aspect Ratio

Use one of the following methods to display a test pattern:

- Press **TEST** on the remote control.  
Use the **LEFT** and **RIGHT** arrow buttons to cycle through the test patterns.
- Press **MENU** open the OSD. Highlight **Test Patterns** from the main menu, then select a test pattern using the **LEFT** and **RIGHT** arrow buttons.

After the final test pattern, the projector exits test pattern mode and returns to the main image. To view test patterns again, you need to press **TEST** again. If you wish to exit the test patterns before you reach the final one, press **TEST** or **EXIT** at any time.

## Adjusting the lens

You can use the following options to adjust the lens:

- Control panel. See Control panel on page 52
- Remote control. See Remote control on page 55
- On screen display (OSD).

### OSD Lens menu

The **Lens** menu provides access to the **Lens Control** setting and the **Lens Center** command.

**Lens Control** allows **Zoom**, **Focus** and **Shift** adjustments using the arrow buttons. The setting operates in **Zoom/Focus Adjustment** and **Shift Adjustment** mode.

Press **ENTER/SELECT** to switch between the two modes.

## Adjusting the image

### Orientation

This can be set from the **Setup** menu.

Highlight **Orientation** and choose from **Front Tabletop**, **Front Ceiling**, **Rear Tabletop**, **Rear Ceiling** and **Auto-front**.

### Geometry

Settings such as **Keystone**, **Rotation**, **Pincushion / Barrel** and **Arc** can be set from the **Geometry** menu.



*For keystone adjustments, open the Lens menu, then open the Lens Type sub menu. Select the correct lens throw ratio. This affects the available options in the Lens Throw Ratio menu for Keystone adjustment.*



*Please refer to the user manual for guidance on every available geometry setting.*

### Picture

Settings such as **Gamma**, **HDR**, **Brightness**, **Contrast**, **Saturation**, **Hue** and **Sharpness** can be set from the **Image** menu.



*Please refer to the user manual for guidance on every available picture setting.*

## Operating the projector

The projector has the following controls:

- Remote control
- Control panel



*Do not make changes to the networking configuration unless you understand what you are doing, or have taken advice from your Network Manager. If you make a mistake, it is possible that you will lose contact with the projector.*

*Always double-check your settings before pressing the APPLY button. Always keep a written note of the original settings, and any changes you have made.*



*Software updates should NOT be carried out except by, or with the supervision of, Digital Projection Service personnel.*

## Control panel

### 1. POWER

Switches the projector on and off (STANDBY).

### 2. SYNC

Press to resynchronise the active input.

### 3. Arrow buttons & ENTER

Press Focus , Lens Shift or Zoom and use the Up and Down arrow buttons to adjust the lens focus, shift or zoom. After opening the OSD, use the arrow buttons to highlight menu entries. Press **ENTER** to open or execute the highlighted menu entry.

### 4. MENU

Press to display or hide the OSD menu.

### 5. MUTE

Shows and hides the projected image. There are two shutter settings:

- Laser. When closed, the laser is switched off and no image is projected
- DMD™ Blanking. When closed, the laser remains on and a black image is projected

### 6. OSD

Press to enable or disable the OSD. When disabled, the OSD cannot be displayed.

### 7. FOCUS

Press this button, then press an arrow button to adjust the focus. Press EXIT to exit the focus mode.

### 8. LENS SHIFT

Press this button, then press an arrow button to adjust the lens shift. Press EXIT to exit the lens shift mode. Press and hold for 5 seconds to center the lens.

### 9. INPUT

Press to move to the next input source.

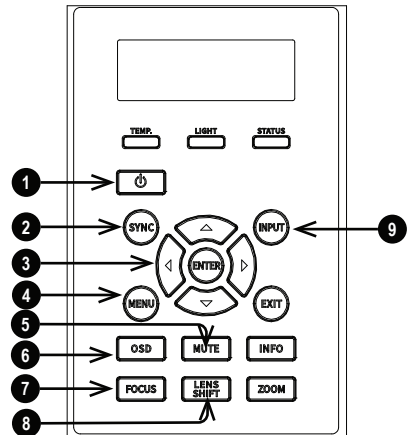

**Control Panel**

- 10. **EXIT**  
Exits the current OSD page and enters the level above.  
Exits the OSD when at the top level OSD page.
- 11. **INFO**  
Press and hold for 5 seconds to activate or deactivate the LCM.  
Press to change pages when the LCM is active.
- 12. **ZOOM**  
Press this button, then press an up or down arrow button to adjust the zoom. Press EXIT to exit the zoom mode.

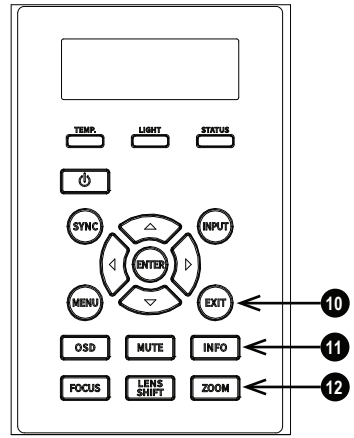

**Control Panel**

## Projector indicators

### 1. LCM

Displays information about the current state of the projector.

### 2. TEMP

Off = no error

Flashing red = temperature error

### 3. POWER

Off = the projector is switched off

Flashing green = the projector is warming up

Flashing amber = the projector is cooling down

On, green = the projector is switched on

On, amber = the projector is in network standby mode

On, red = the projector is in power saving standby mode

### 4. LIGHT

Off = light source is switched off

On, amber = light source is on (forced ECO mode)

On, green = light source is switched on

Flashing red (cycle of single flashes)  
= failed to light up during power up

Flashing red (cycles of double flashes)  
= light source failed while projector is on

Flashing green (cycles of single flashes)

= light source is temporarily off as PIC Mute is activated

### 5. STATUS

Off = no error

On, amber = firmware update mode

On, red = system error

Flashing green (cycles of double flashes) = lens calibration mode

Flashing amber (cycles of double flashes) = request to recalibrate the lens

Flashing red (cycle of single flashes) = cover error

Flashing red (cycles of double flashes) = TEC/Color sensor problem

Flashing red (cycles of four flashes) = fan error

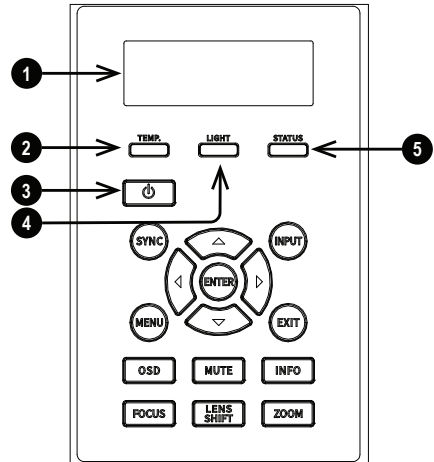

**Indicators**

## Remote control

### 1. Power ON / OFF

Turns power on and off.

### 2. Pic Mute OPEN / CLOSE

- Press CLOSE to hide the projected image. There are two PIC Mute settings:

- Laser. When off, the laser is switched off and no image is projected
- DMD™ Blanking. When off, the laser remains on and a black image is projected

- Press OPEN to display the hidden image.

### 3. OSD ON / OFF

Enable and disable screen timeout messages and control whether to show the OSD during projection.

### 4. MENU

Access the on screen display (OSD). If the OSD is open, press this button to go back to the previous menu.

### 5. Navigation (arrows and OK)

**OSD mode:** Navigate through the menus with the arrows, confirm your choice with **OK**.

**Lens adjustment modes:** See **10** below.

### 6. EXIT

Go up one level in the OSD. When the top level is reached, press to close the OSD.

### 7. DEFAULT

When editing a parameter, press this button to restore the default value.

### 8. INFO

Access information about the projector.

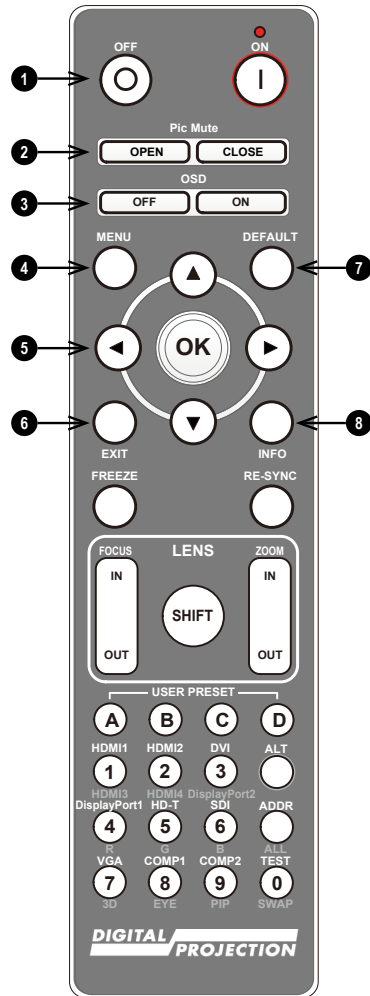

**Remote Control**

9. **FREEZE**  
Freeze the current frame.
10. **LENS adjustment**
  - **FOCUS IN / OUT:** adjust focus.
  - **SHIFT:** press and hold this button, then use the OK and Navigation buttons. Press OK to switch between **Shift Adjustment** and **Zoom / Focus Adjustment**. Use the arrows to shift, zoom or focus the lens.
  - **ZOOM IN / OUT:** adjust zoom.
11. **USER PRESET A, B, C, D**  
Load user presets.
12. **RE-SYNC**  
Re-synchronise with the current input signal
13. **ALT**  
Press and hold this button to access alternative functions for other buttons on the remote.
14. **DVI / DisplayPort2 / numeric input 3**  
There is no DVI input on this projector.  
Use with **ALT** to select the DisplayPort 2 input.
15. **HDMI 2 / HDMI 4 / numeric input 2**  
Select the HDMI 2 input.  
There is no HDMI 4 input on this projector
16. **HDMI 1 / HDMI 3 / numeric input 1**  
Select the HDMI 1 input.  
There is no HDMI 3 input on this projector

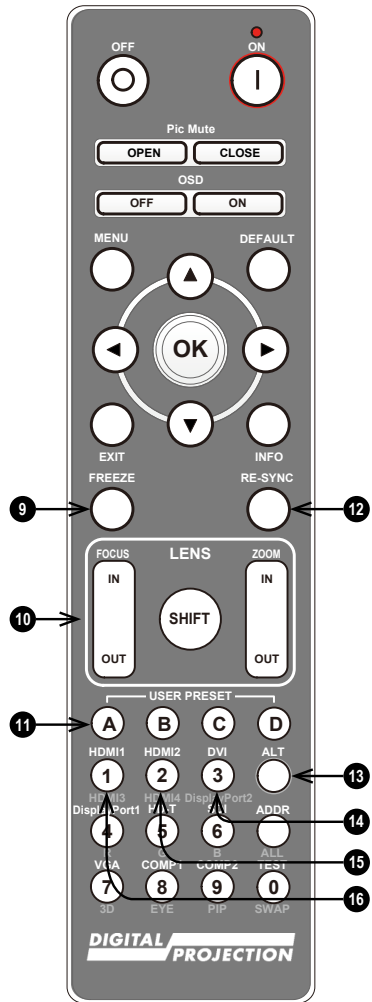

**Remote Control**



- 17. **DISPLAYPORT 1 / R / numeric input 4**  
Select DisplayPort 1 input.

- 18. **HD-T / G / numeric input 5**  
Select the HDBaseT input.

- 19. **ADDR / ALL (with red indicator at the top)**  
Assign and unassign an IR remote address.

**To assign an IR remote address:**

1. Press and hold this button until the red indicator starts flashing.
2. Release this button and while the red indicator is still flashing, enter a two-digit address using the numeric input buttons. The indicator will flash three times quickly to confirm the change.

**To unassign an address and return to the default address 00:**

1. Press and hold ALT and this button simultaneously until the red indicator flashes to confirm the change.

- 20. **SDI / B / numeric input 6**  
There is no SDI input on this projector.

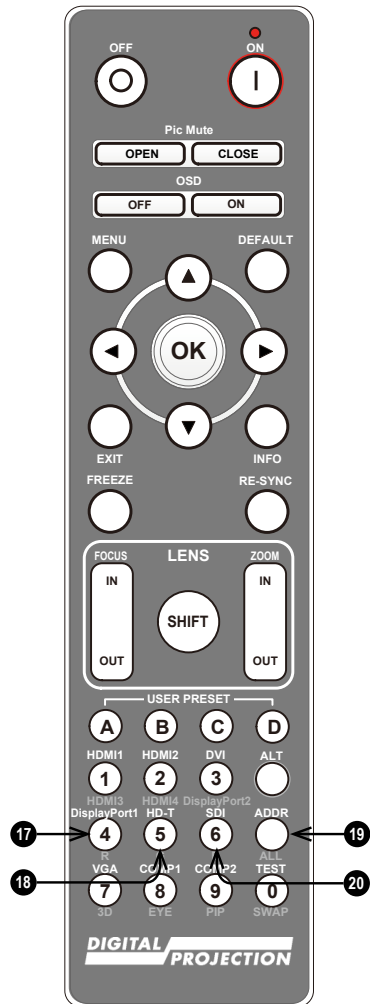

**Remote Control**

- 21. **VGA / 3D / numeric input 7**  
 There is no VGA input on this projector.  
 Use with **ALT** to toggle the 3D Format setting between Off and Auto.
- 22. **COMP1 / EYE / numeric input 8**  
 There is no Component 1 input on this projector.  
 Use with **ALT** to switch between left and right eye 3D dominance.
- 23. **TEST / SWAP / numeric input 0**  
 Show a test pattern. Press again to show the next test pattern: Off, White, Black, Red, Green, Blue, Checkerboard, Crosshatch, Color Bar, Aspect Ratio  
 When **PIP** mode is on, use this button with **ALT** to swap the main and sub images.
- 24. **COMP2 / PIP / numeric input 9**  
 There is no Component 2 input on this projector.  
 Use with **ALT** to switch on Picture In Picture (PIP) mode.

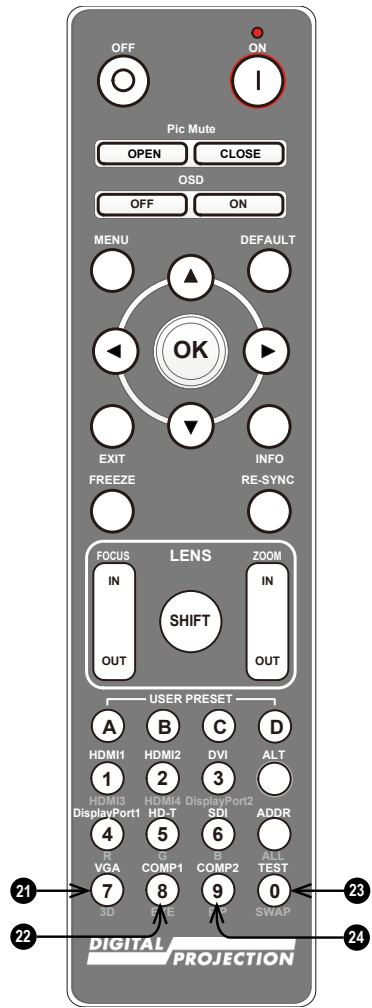

**Remote Control**

This page is intentionally left blank

## Contact Information

### Europe

Digital Projection Limited

Unit 3 Aniseed Park, Oldham  
Broadway Business Park,  
Oldham, England, OL9 9XA

*Registered in England No.*  
*03287264*

*Registered Office: As Above*

Tel: (+44) 161 947 3300

enquiries@digitalprojection.co.  
uk

service@digitalprojection.co.uk

www.digitalprojection.co.uk

### North America

Digital Projection Inc.

55 Chastain Road, Suite 115,  
Kennesaw, GA 30144, USA

Tel: (+1) 770 420 1350

Fax: (+1) 770 420 1360

contact@digitalprojection.com

www.digitalprojection.com

### China

Digital Projection China

中国北京市朝阳区芍药居  
北里101号世奥国际中心A座  
2301室(100029)

Rm A2301, ShaoYaoJu 101  
North Lane, Shi Ao  
International Center,  
Chaoyang District, Beijing  
100029, PR CHINA

Tel: (+86) 10 84888566

Fax: (+86) 10 84888566-805

techsupport@dp-china.com.cn

www.dp-china.com.cn

### India

Digital Projection India

Plot-43, Sector-35, HSIIDC,  
Gurgaon Haryana -122001

Tel: +91-124-4874900#4275

india@digitalprojection.co.uk

### Japan

Digital Projection Japan

〒105-0012 東京都港区芝大  
門2-1-14

2-1-14 Shibadaimon, Minato-  
ku, Tokyo, Japan 105-0012

japan@digitalprojection.co.uk

www.digitalprojection.com/jp

### Taiwan

Digital Projection Taiwan

186 Ruey Kuang Rd, Neihu  
District, Taipei, 114 Taiwan

Tel: +886-8797-2088 x8854

Taiwan@digitalprojection.co.uk

### Korea

Digital Projection Korea

1511, Byucksan Digital Valley 6-  
cha, Gasan-dong,  
Geumcheon-gu, Seoul, Korea

Tel: (+82) 2 515 5303 #1417

Korea@digitalprojection.co.uk